

Parts Manual

Mfg. No: 1172-0
2,250 PSI



Model Components	Page
Pressure Washer.....	4
Pump.....	8
Torque Specification Chart.....	12

Not For
Reproduction

Pressure Washer

Note: Unless noted otherwise, use the standard torque specifications

Mfg. No: 1172-0

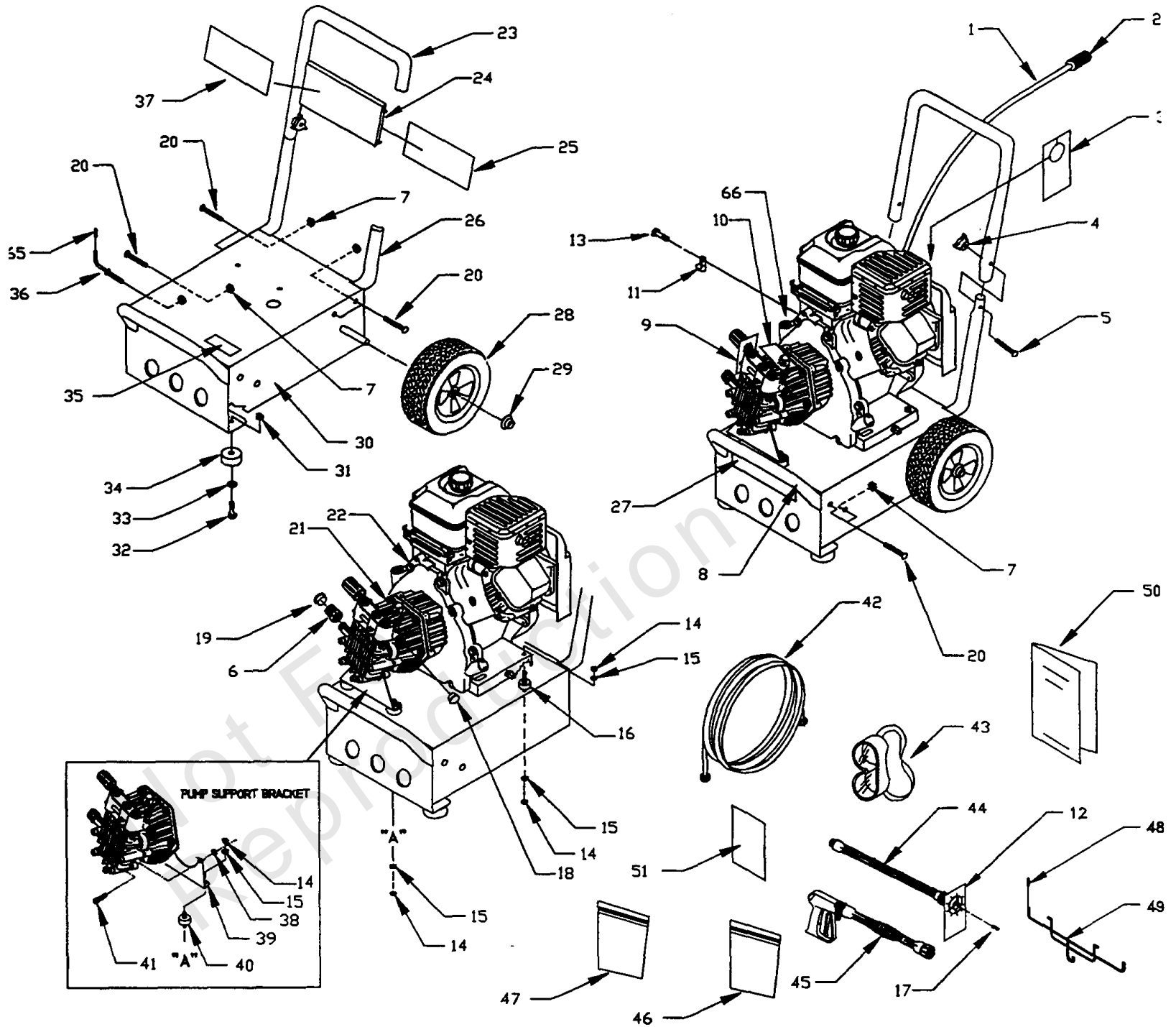

Pressure Washer

REF NO	PART NO	QTY	DESCRIPTION
1	A1040D	1	HOSE, 4-1/2' Chemical Clear
2	A1041	1	FILTER, Chemical Hose
3	94481	1	TAG, Warning Oil -(English/French)
4	97178	2	KNOB, Handle 1/4-20 PW
5	31669	2	BOLT, 1/4-20 x 1-3/4 Carriage
6	21424	1	CONNECTOR, Garden Hose
7	99583	8	NUT, Range Lock 5/16-28
8	B1982	1	BUMPER
9	98944	1	TAG, Pres. Adjust -(English/French)
10	B1288	1	TAG, PW Breather Cap -(Tr-Lingual)
11	B2718	1	CLAMP, Hose 7/16" Dia.
12	98904	1	TAG, Nozzle
13	32713	1	SCREW, Taptite #10-32 x 5/8" Lg
14	45771	8	NUT, M8-1.25 Hex
15	22129	8	LOCKWASHER, M8
16	21217	2	MOUNT, Rubber Shock
17	B1236F	1	NOZZLE, Replacement 1.25 mm
18	97100	1	CAP, H.P. Adaptor
19	97098	1	CAP, Garden Hose Inlet
20	B2043	7	BOLT, 5/16-18 x 1/4" Carriage
21	-----	1	ASSEMBLY, Pump -(For Replacement, order 198347GS)
21	198347GS	1	REPLACEMENT PUMP ASSEMBLY
22	B1827	1	ENGINE
23	B1983	1	HANDLE
24	B1631A	1	BILLBOARD, Plastic
25	B2772	1	DECAL Instructions
26	B1981	2	SUPPORT, Handle
27	B2192	1	DECAL, Generac
28	B1760	2	ASSEMBLY, 10" Tire & Wheel
29	75402	2	PUSHNUT, .50 Dia.
30	AB1770	1	BASE
31	52858	2	NUT, M8 1.25 Locking
32	42909	2	HHCS, M8 1.25 x 30
33	50190	2	WASHER, M8 Flat
34	27007	2	MOUNT, Donut Type Vibration
35	20566	1	DECAL Generac #1-800 -(English)
36	B2150	1	HOOK, Gun
37	B2146	1	DECAL, Logo
38	52857	2	NUT, M6 1.0 Locking
39	20707	1	BRACKET, Pump Support
40	21216	2	MOUNT, Rubber Shock
41	38750	2	HHCS, M6 1.0 x 30
42	B1969	1	HOSE, High Pressure
43	87815	1	GOGGLES, safety
44	B1867F	1	WAND
45	B1861	1	GUN, High Pressure
46	B2203	1	KIT, Handle Fastening
47	B2163	1	KIT, Cleaning

Pressure Washer

Note: Unless noted otherwise, use the standard torque specifications

Mfg. No: 1172-0

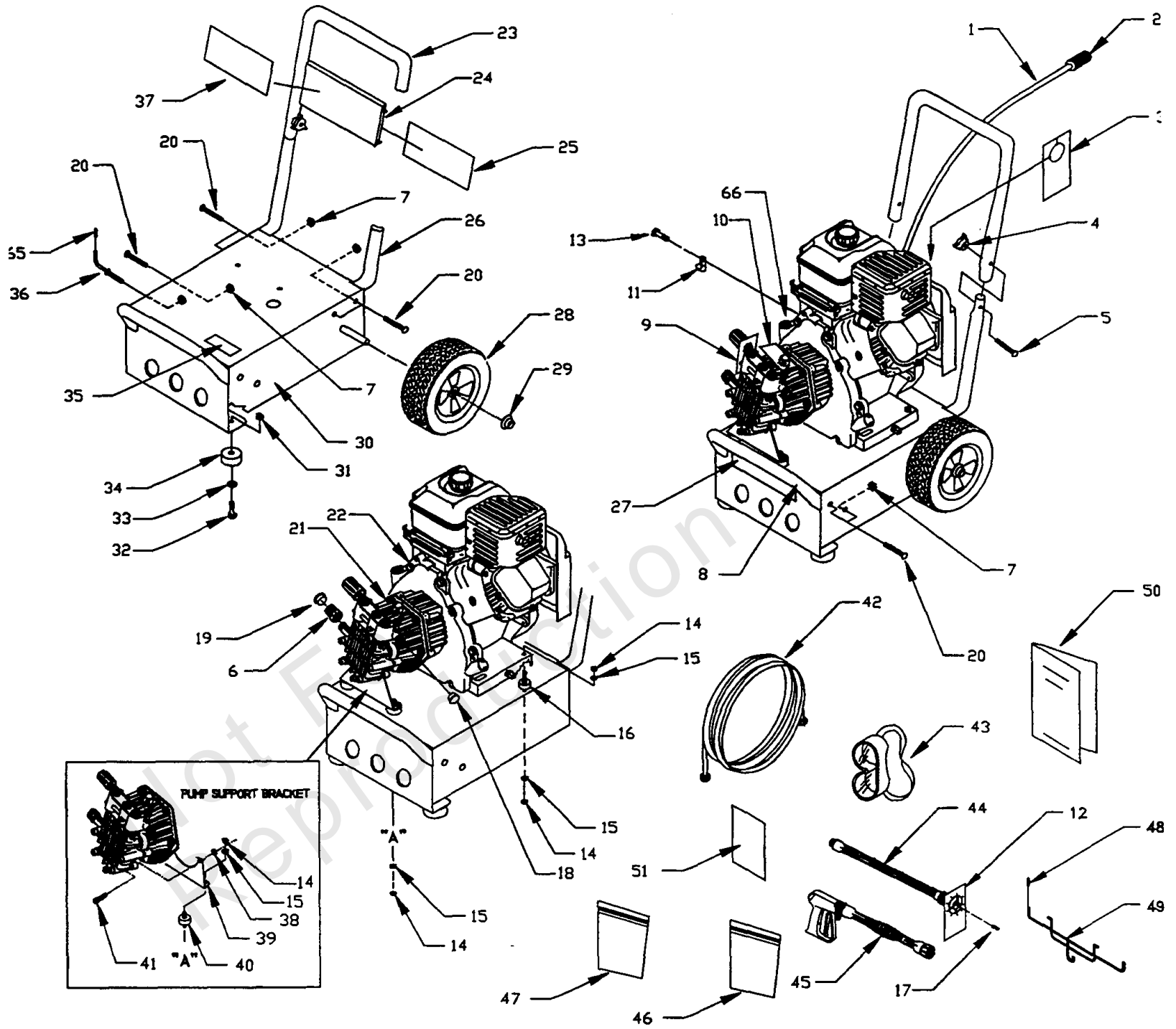

Pressure Washer

REF NO	PART NO	QTY	DESCRIPTION
48	B1460	2	CAP, Vinyl -(Black)
49	B2168	1	HANGER, Hose, Gun, Jug
50	B2775	1	MANUAL, English/French
51	98906	1	SHEET, Nozzle Cleaning -(French)
65	B2516	1	CAP, Vinyl -(Black)
66	95441	1	SPACER, Engine Pilot -(Not shown)

Not For Reproduction

Pump

Note: Unless noted otherwise, use the standard torque specifications

Mfg. No: 1172-0

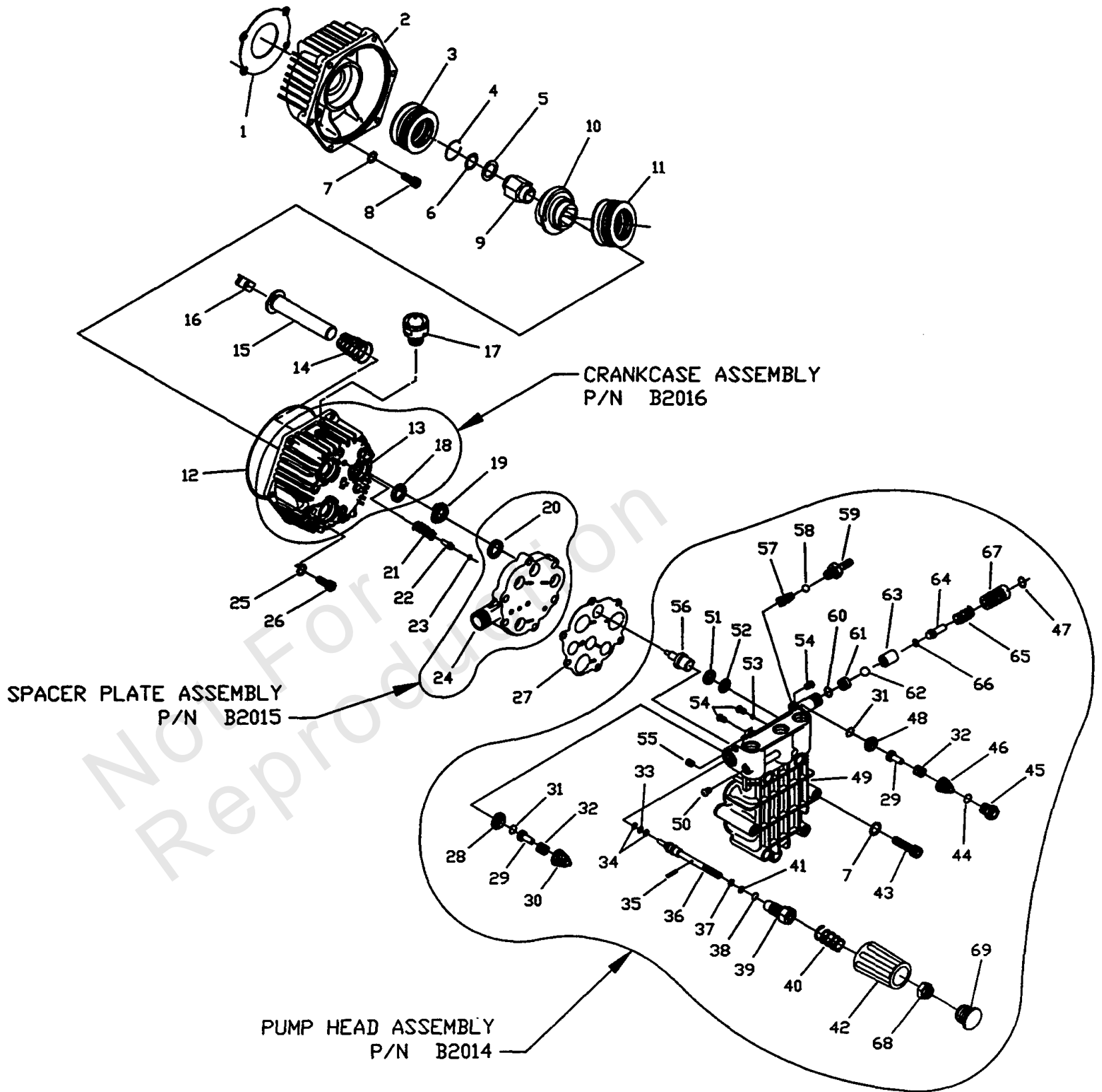

Pump

REF NO	PART NO	QTY	DESCRIPTION
1	93871	1	GASKET, Engine Adapter
2	96430A	1	ADAPTER, Engine
3	96542	1	BEARING Eng. Adptr. Roller Thrust 4 x
4	97675	1	C - RING, Cam Retainer
5	97570	1	WASHER, Thrust
6	95524	1	WASHER, Retainer
7	92479	10	LOCKWASHER, M8 Ribbed
8	95531	4	BOLT, SHC 5/16-24 x 3/4" Lg
9	95435	1	ADAPTER, Engine Shaft 3/4"
10	21277V	1	CAM, Axial 7.5 Lift
11	97606	1	BEARING Axial Cam Roller Thrust 5.5 x 4
12	93790	1	"O" RING Crankcase 113.97 x 119.21 x 2.62
13	97568A	1	CRANKCASE, Pump
14	96400	3	SPRING, Piston Return
15	99427	3	ASSEMBLY, Ceramic Piston & Cap
16	94944	3	SHOE, Piston Pivot
17	99735	1	ASSEMBLY, Breather
18	93680	3	SEAL, Oil Piston
19	93668	3	SPACER, Pilot
20	93667	3	SEAL, U - Cup ELF
21	93652	1	SPRING Thermal Relief Actuator
22	95416	1	PISTON, Thermal Relief Actuator
23	93876	1	"O" RING Thermal Relief 2.9 x 6.5 x 1.78
24	A1320	1	SPACER, Inlet Plate
25	93873	6	LOCKWASHER, M6 Ribbed
26	40945	6	SCREW, SHC M6 x 1.0 x 20 mm Lg
27	A2069	1	GASKET, Head
28	A2062	3	SEAT, Check Valve Inlet
29	A2060	6	POPPET, Check Valve
30	97931	3	CAGE, Check Valve Inlet
31	97934	6	"O" RING, Chk Valve 12.4 x 15.96 x 1.78
32	97929	6	SPRING Check Valve Outlet
33	97843	1	"O" RING 9.25 x 12.81 x .78
34	A2017	2	PAR - BACK, Backup Ring
35	A1719	1	PIN, 2.0 Dia. Spindle
36	A1711	1	SPINDLE, Pressure Regulator
37	93656	1	"O" RING Spindle 1/4 x 3/8 x 1/16 cs
38	A3829	1	"O" RING, Retainer Nut 14 x 17.56 x 1.78
39	A1712	1	NUT, Retainer- Spindle
40	A1716	1	SPRING, Unloader
41	A2016	1	PAR-BACK, Backup Ring
42	A2039	1	HANDLE, Unloader
43	A2013	6	BOLT, Head M8 x 1.25 x 70mm Lg
44	97840	3	"O" RING, Chk Valve Cap 15.6 x 19.16 x 1.78
45	97841	3	CAP, Outlet Port
46	20002	3	CAGE, Check Valve Outlet
47	A3805	1	"O" RING, Venturi 10.82 x 14.38 x 1.78
48	A2217	3	SEAT, Check Valve Outlet
49	A1318	1	CYLINDER, Head
50	B1758	1	PLUG, Button M8 x 1.25 x 8 mm
51	96053	3	SEAL, High Pressure

Pump

Note: Unless noted otherwise, use the standard torque specifications

Mfg. No: 1172-0

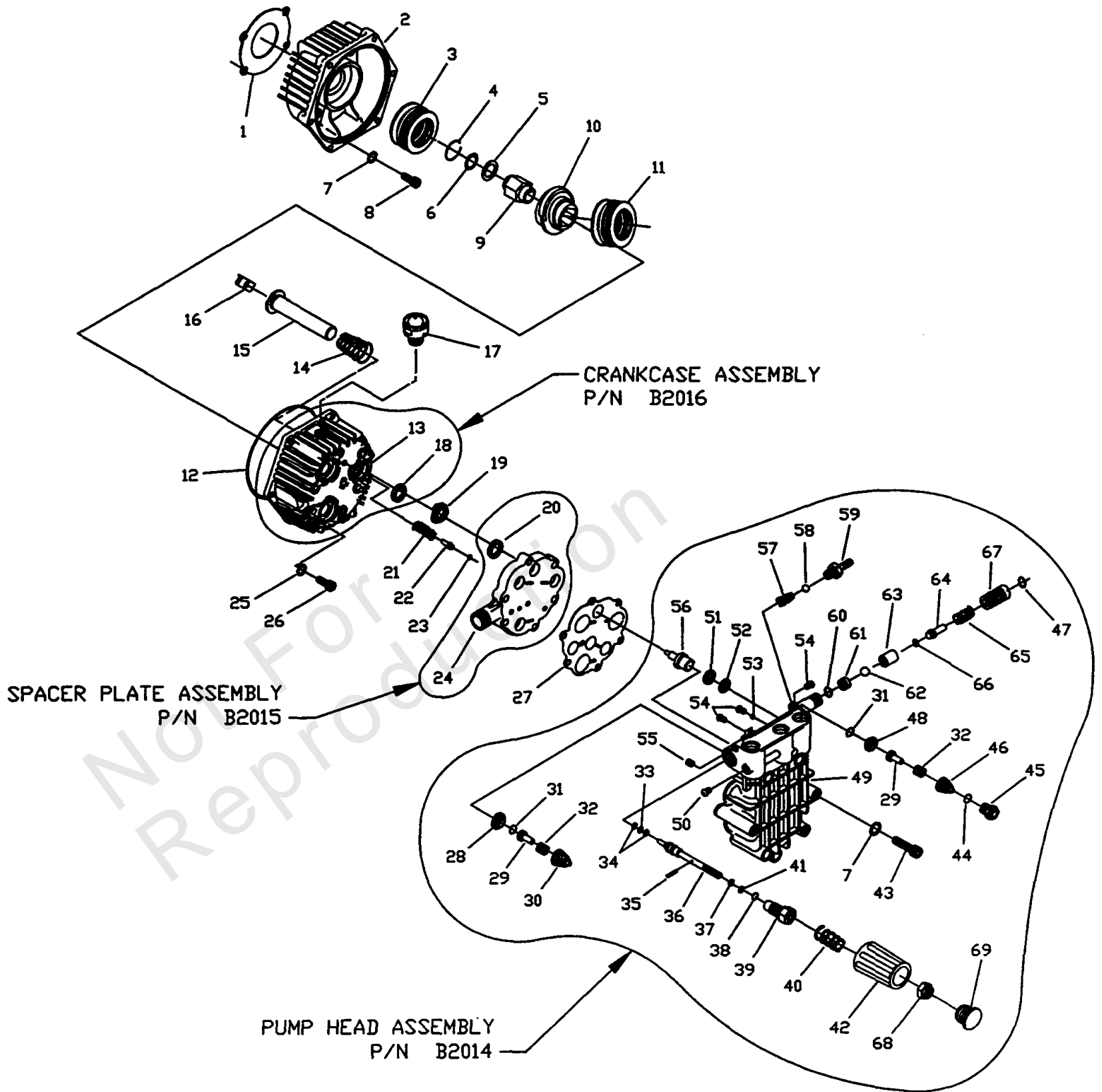

Pump

REF NO	PART NO	QTY	DESCRIPTION
52	96015	3	RING Bearing
53	A1717	1	MAGNET, Ball Deflector
54	B1757	4	PLUG, Button M6x10x8mm
55	A1718	1	SETSCREW, M8-1.25 x 8mm
56	93644	1	ACTUATOR, Thermal Relief
57	95380	1	SPRING Chemical Injector
58	95379	1	BALL, 5.5 dia. Chemical Injector
59	A1575	1	BARB HOSE, Brass with Nylon Insert
60	97855	1	"O" RING Ball Seat 6.5 x 10.5 x 2 cs
61	A1713	1	SEAT, Ball Unloader
62	A2015	1	BALL, Stainless Steel 9/32 Dia.
63	A2503	1	SEAT, Trapped Line Pressure
64	A2756	1	VALVE, Shuttle Piston
65	89138	1	SPRING, Check Valve
66	21123	1	"O" RING, 3.68 x 7.24 x 1.78 cs
67	A1714	1	VENTURI, Chemical
68	B2236	1	LOCKNUT, M6 x 1.0 Nylon
69	B2241	1	CAP, Plastic

Hardware Identification & Torque Specifications

Torque Specification Chart								
FOR STANDARD METRIC MACHINE HARDWARE (Tolerance ± 20%)								
Property Class	5.6		8.8		10.9		12.9	
	Class 5.6		Class 8.8		Class 10.9		Class 12.9	
Size Of Hardware	in/lbs	Nm.	in/lbs	Nm.	in/lbs	Nm.	in/lbs	Nm.
	ft/lbs		ft/lbs		ft/lbs		ft/lbs	
M3	5.88	.56	13.44	1.28	19.2	1.80	22.92	2.15
M4	13.44	1.28	30.72	2.90	43.44	4.10	52.56	4.95
M5	26.4	2.50	60.96	5.75	5.97	8.10	7.15	9.7
M6	44.64	4.3	7.3	9.9	10.3	14	12.1	16.5
M7	5.2	7.1	12.1	16.5	16.9	23	19.9	27
M8	7.7	10.5	17.7	24	25	34	29	40
M10	15	21	35	48	50	67	59	81
M12	26	36	61	83	86.2	117	103	140
M14	42	58	101	132	136	185	162	220
M16	64	88	147	200	210	285	250	340
M18	89	121	202	275	287	390	346	470
M20	126	171	290	390	405	550	486	660
M22	169	230	390	530	559	745	656	890
M24	217	295	497	375	708	960	840	1140
M27	320	435	733	995	1032	1400	1239	1680
M30	435	590	995	1350	1401	1900	1681	2280
M33	590	800	1349	1830	1902	2580	2278	3090
M36	759	1030	1740	2360	2441	3310	2935	3980
M39	988	1340	2249	3050	3163	4290	3798	5150

Torque Specification Chart						
FOR STANDARD MACHINE HARDWARE (Tolerance ± 20%)						
Hardware Grade	No Marks		SAE Grade 5		SAE Grade 8	
	SAE Grade 2		SAE Grade 5		SAE Grade 8	
Size Of Hardware	in/lbs	Nm.	in/lbs	Nm.	in/lbs	Nm.
	ft/lbs		ft/lbs		ft/lbs	
8-32	19	2.1	30	3.4	41	4.6
8-36	20	2.3	31	3.5	43	4.9
10-24	27	3.1	43	4.9	60	6.8
10-32	31	3.5	49	5.5	68	7.7
1/4-20	66	7.6	8	10.9	12	16.3
1/4-28	76	8.6	10	13.6	14	19.0
5/16-18	11	15.0	17	23.1	25	34.0
5/16-24	12	16.3	19	25.8	29	34.0
3/8-16	20	27.2	30	40.8	45	61.2
3/8-24	23	31.3	35	47.6	50	68.0
7/16-14	30	40.8	50	68.0	70	95.2
7/16-20	35	47.6	55	74.8	80	108.8
1/2-13	50	68.0	75	102.0	110	149.6
1/2-20	55	74.8	90	122.4	120	163.2
9/16-12	65	88.4	110	149.6	150	204.0
9/16-18	75	102.0	120	163.2	170	231.2
5/8-11	90	122.4	150	204.0	220	299.2
5/8-18	100	136	180	244.8	240	326.4
3/4-10	160	217.6	260	353.6	386	525.0
3/4-16	180	244.8	300	408.0	420	571.2
7/8-9	140	190.4	400	544.0	600	816.0
7/8-14	155	210.8	440	598.4	660	897.6
1-8	220	299.2	580	788.8	900	1,244.0
1-12	240	326.4	640	870.4	1,000	1,360.0

The guides and ruler furnished below are designed to help you select the appropriate hardware.



Nut, M8

Thread Diameter (mm)

Inside Diameter (in) Threads per inch

Nut, 1/2-16

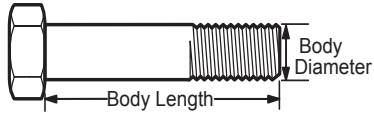

Screw, M8- 1.25 x 25

Thread Diameter (mm) Distance between threads (mm) Body Length (mm)

Body Diameter Threads per inch Body Length (in)

Screw, 1/2- 16 x 2



Standard Hardware Sizing

When a washer or nut is identified as 1/2" (M8), this is the *Nominal size*, meaning the *inside diameter* is 1/2 inch (8mm metric thread diameter); if a second number is present it represents the *threads per inch* (distance between threads).

When bolt or capscrew is identified as 1/2 - 16 x 2" (M8 - 1.25 x 50), this means the *Nominal size*, or body diameter is 1/2 inch (8mm metric thread diameter), the second number, 16, represents the *threads per inch*, (*distance between threads*). The final number is the body length of the bolt or screw, 2 inches (50mm).

NOTES

- These torque values are to be used for all hardware excluding: locknuts, self-tapping screws, thread forming screws, sheet metal screws and socket head setscrews.
- Recommended seating torque values for locknuts:
 - for prevailing torque locknuts - use 65% of grade 5 torques.
 - for flange whizlock nuts and screws - use 135% of grade 5 torques.
- Unless otherwise noted on assembly drawings, all torque values must meet this specification.

Common Hardware Types

Hex Head Capscrew

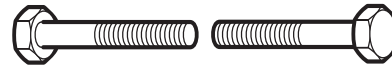

Washer



Carriage Bolt

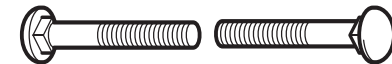

Hex Nut

Wrench & Fastener Size Guide

1/4" Bolt or Nut Wrench—7/16"	5/16" Bolt or Nut Wrench—1/2"	3/8" Bolt or Nut Wrench—9/16"	7/16" Bolt or Nut Wrench (Bolt)—5/8" Wrench (Nut)—11/16"	1/2" Bolt or Nut Wrench—3/4"
M6 Bolt or Nut Wrench—10mm	M8 Bolt or Nut Wrench—13mm	M10 Bolt or Nut Wrench—17mm	M12 Bolt or Nut Wrench—19mm	M14 Bolt or Nut Wrench—22mm

